

SPECIFICATIONS:

- Vitreous china
- High efficiency 4.8Lpf / 1.28Gpf
- Elongated 17" Plus Height bowl
- Chrome side tank lever
- Lined tank
- 12" Rough-in
- 3" long-life flush valve
- 2" fully glazed trapway
- Plastic smooth close toilet seat included
- 100% factory flush tested

OVERALL DIMENSIONS:

420mm (W) x 695mm (D) x 825mm (H)
 16½" (W) x 27¾" (D) x 32½" (H)

SHIPPING:

Cube 7.19
GW 100 lbs

COMPLIANCE CERTIFICATIONS:

Meets or exceeds the following specs:

- IAPMO cUPC
- ASME A112.19.2 / CSA B45.1
- US EPA WaterSense
- ADA Guidelines & ANSI A117.1
- MaP Tested 1000g



ITEM TO BE SPECIFIED:

SOFT WHITE:

TL-7249CE-WL

UPC: 721015428930



The compact elongated bowl provides you the elongated feature with the same depth as a round front bowl.



The newly designed enlarged footprint covers most existing floor marks.

Products are designed to comply ADA/ANSI A117.1 Standard. It shall be the responsibility of the installer to comply with the local disability codes and standards prior to installing the product.

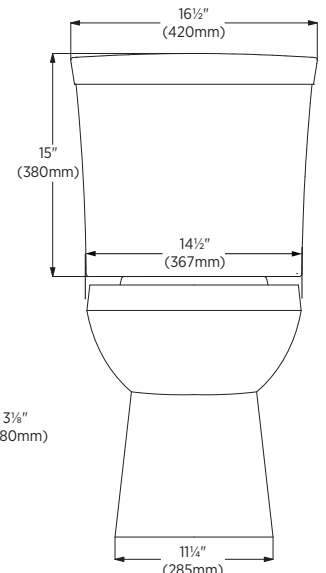
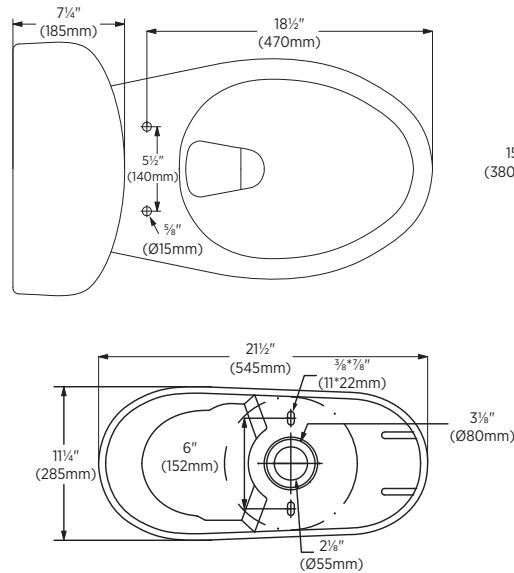
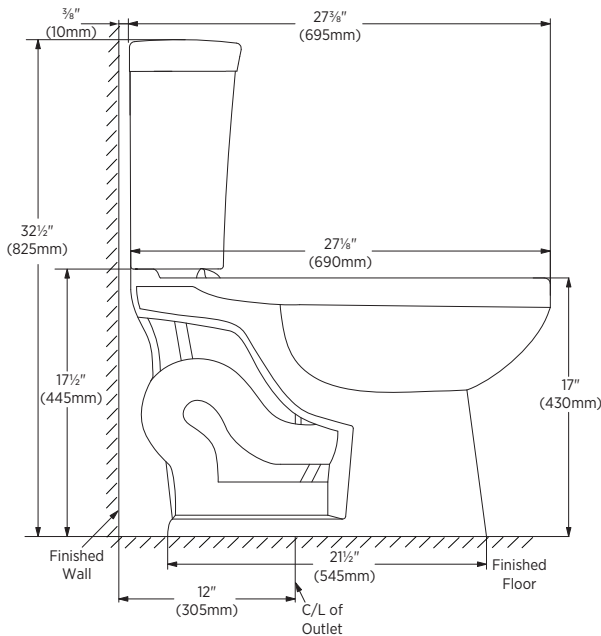

Notes:

Important: Dimensions of product are nominal and may vary within the range of tolerances allowed. These measurements are subject to change or cancellation. No responsibility is assumed for use of superseded or voided pages.